

LENTON[®]

Instruction Manual

CADWELD[®] for Rebar Splicing System

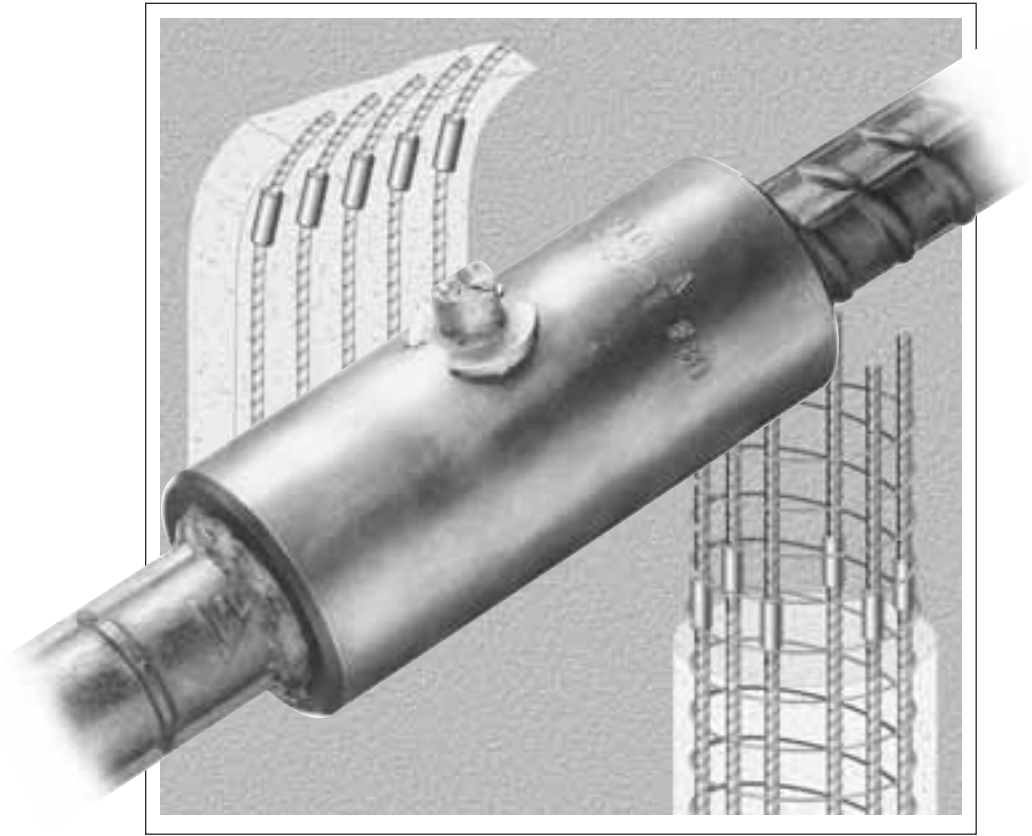

ERICO[®]

IMPORTANT

General and Safety Information

- A. Only ERICO® manufactured equipment and materials should be used to make CADWELD® rebar splices.
 - 1. Do not splice except as detailed in the instructions.
 - 2. Do not use worn or broken equipment that could cause leakage.
 - 3. Do not alter equipment or material without factory authorization.
 - 4. Do not substitute for specified ERICO manufactured equipment and materials.Failure to comply with the above may result in hazards to the individual, improper splices, or damage to items being spliced.

- B. Make splices in accordance with described splicing procedures and in consideration of surrounding conditions and personnel. Refer to ANSI Z-49.1 SAFETY IN WELDING AND CUTTING and your local safety procedures.
 - 1. Personnel should be properly trained in the use of this product.
 - 2. Avoid breathing concentrations of smoke, as it may be hazardous to health.
 - 3. Avoid contact with hot materials.
 - 4. Advise nearby personnel of splicing operation in the area.
 - 5. Remove or protect fire hazards in the immediate area.
 - 6. Do not smoke when handling starting material.

- C. Adhering to the recommended splicing procedures will minimize risk of burns and fire caused by hot molten material spillage.
 - 1. Make sure there is proper fit and assembly of equipment.
 - 2. Avoid moisture and decomposable contaminants on splicing equipment and rebar.
Contact of hot molten metal with moisture or contaminants may result in spewing of hot material.

- D. Unusual applications or conditions may exist which require special considerations.
 - 1. Provide adequate ventilation where natural air flow is not sufficient to prevent personnel breathing concentrations of smoke.

- E. Storage of CADWELD filler material should be in a clean, dry, "No Smoking" area and should be restricted to access by authorized personnel only.
 - 1. Starting material and filler material are exothermic mixtures and react to produce hot molten materials with temperatures in excess of 2200°C (4000°F) and a localized release of smoke. These materials are **NOT** explosive. Ignition temperatures are in excess of 450°C (850°F) for starting material and 900°C (1650°F) for filler material.
 - 2. In case of fire, water or CO₂ will aid in control of burning containers. Large quantities of water will aid in controlling a fire should the exothermic materials become involved. Water should be applied from a distance.

- F. CADWELD filler material in the work area should be protected from spatter and hot materials to prevent accidental ignition. Use a covered wood or metal gang box for storage of materials not for immediate use.

- G. Dispose of slag from the CADWELD splicing process in a steel container that has a layer of dry sand in the bottom. The sand is necessary to prevent burn through.

- H. See splicing instructions enclosed for additional information.

Table Of Contents

General Safety Information.....	IFC
Rebar Cleaning Procedure (Preparation)	2
Instructions for Vertical Splicing (Bar-to-Bar)	3-4
Instructions for Horizontal Splicing	5-6
Filler Material Remixing and Placement Procedures.....	7
Venting CADWELD® Horizontal Splices	8
Inspection	9
Eccentricity and Cocking of Rebars	9
Rejection of a Splice and Its Causes.....	10
Void Limits.....	11
Additional Instructions for B-Series.....	12
Welding of Splice Sleeves to Structural Steel.....	12
Care of Finished Assemblies.....	12
Addenda	13
External Bar Reference Marks	13
Bar End Gap	13
B-Series Sleeve Repair.....	13
Tap Hole Relocation.....	14
Use of Sleeves Out of Their Normal Position.....	15
Repair of Bar-to-Bar Production Splice Samples or Rejected Splices.....	15
Traceability.....	15

Rebar Cleaning Procedure (Preparation)

1. Rebar ends to be spliced must be dry and free of excessive rust, loose mill scale, dirt, paint, concrete, etc. Clean back from bar end at least one-half sleeve length.

2. Cleaning Procedure

2.1 Torch and Power Brushing (See notes)

2.1.1 Flame dry ends to remove moisture and/or burn away any other foreign contaminants. Flame should be soot free and not leave any residue or deposits on bar ends. A "rosebud" torch tip is recommended.

2.1.2 Remove excessive rust and all loose mill scale, dirt, paint, concrete, etc. with a power wire brush.

2.1.2.1 Heavy duty, low speed (200-350 rpm), reversible drill is recommended for use with ERICO® brand of cleaning brushes (Series RBW343). See catalog for additional information.

2.1.2.2 1000 rpm or higher is recommended for wire wheel and cup brushes.

2.1.3 Repeat steps 2.1.1 and 2.1.2 on extremely bad bar surfaces.



2.2 Torch and Sandblasting

2.2.1 Sandblast bar ends clean.

2.2.2 Flame dry ends to remove moisture. Flame should be soot free and not leave any residue or deposits on bar ends. A "rosebud" torch tip is recommended.

2.3 Torch and Hand Wire Brushing (See notes)

2.3.1 Flame dry ends to remove moisture and/or burn away any other foreign contaminants. Flame should be soot free and not leave any residue or deposits on bar ends. A "rosebud" torch tip is recommended.



2.3.2 Should lack of power or clearance restrictions prevent the use of power-driven equipment, remove excessive rust and all loose mill scale, dirt, paint, concrete, etc. with a hand wire brush.

2.3.3 Repeat steps 2.3.1 and 2.3.2 on extremely bad bar surfaces.

2.3.4 Wipe bar ends with a clean, dry rag to remove any dust.

3. Badly deformed bar ends may require cutting to assure easy fit of the sleeve. Bar end shear "drags" may be flame cut or ground off. Oversize longitudinal ribs should only be ground as flame cutting may damage the bar, especially on higher strength steels. The longitudinal ribs should not be ground below the height of the bar deformations.

4. Cleaned bar ends that must be left out overnight should be protected (use empty plastic filler material bags) and must be re-dried and re-cleaned if necessary.

NOTES:

1. Brushes must be kept free of grease, oil, and/or other contaminants that could evolve gas and cause porosity in filler material.

2. Eye protection should be worn when using power-driven cleaning brushes.

3. Do not reverse the rebar cleaning brush while it is engaged with the rebar.



Instructions For Vertical Splicing (Bar-to-Bar)

1. Clean rebar ends as per "Rebar Cleaning Procedure" on page 2, as required.



2. Position bottom support clamp and end alignment fitting so end of rebar will be at tap hole opening of sleeve.
"T" shaped support rod on bottom support clamp should be in line with the sleeve tap hole so that support will be directly beneath the pouring basin.

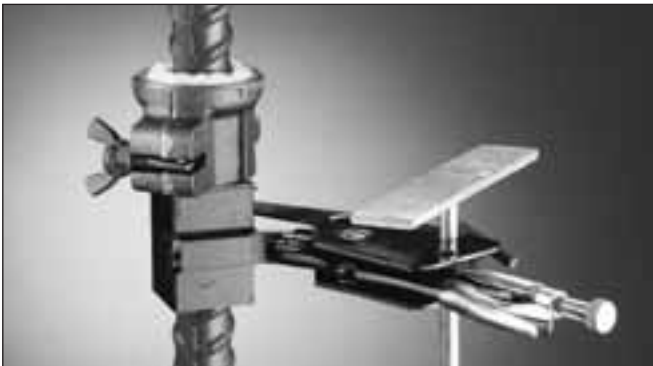

3. Place a double wrap of packing material into position in the lower end alignment fitting. Using a blunt screwdriver, place the first wrap around the bar into the space between the bar and end alignment fitting. The second wrap around the bar is placed loosely above the first.



4. Place splice sleeve into lower fitting and seat firmly against the packing to seal lower end of sleeve.



5. Lower top rebar into position. The average gap between bar ends should not exceed 1/4-in. (6mm). If a natural gap is not provided by the shape of the reinforcing bar ends, a spacer can be used.

Spacers are enclosed in an envelope in each carton of CADWELD® ferrous filler material.

Both bar ends should be visible through the sleeve tap hole.

6. Place a single wrap of packing material loosely around bar on top of splice sleeve; DO NOT PACK.



7. Place end alignment fitting on top of splice sleeve; position ceramic insert guide tube assembly firmly into taphole, making sure it is completely seated inside the hole.

8. Flame dry pouring basin and crucible before using. As a check, a drop of water should boil off rapidly.



Instructions For Vertical Splicing (Bar-to-Bar)

9. With pouring basin frame handles unlocked and pouring basin slightly open, place the pouring basin around the ceramic insert and against the splice sleeve. Close pouring basin frame handles and lock. Place chain around the sleeve and finger tighten thumb nut. Be sure to support the pouring basin while securing chain to prevent unseating of the sleeve against the bottom packing.

Adjust "T" shaped support rod against bottom of pouring basin. Support rod should just touch and support levelled pouring basin DO NOT force pouring basin up.

NOTE: A crucible should not be reused until allowed to cool for 15 minutes or more. If more frequent use is desired, several crucibles complete with frames should be used alternately to allow sufficient cooling time. Clean crucible thoroughly inside. Empty the crucible completely, see Note 15 & 16 on this page for additional information. **DO NOT use a wire brush.**

10. Place crucible ceramic insert assembly in bottom of crucible. **All crucibles use the same ceramic insert.**

11. The crucible ceramic insert assembly is supplied with a steel disk pre-installed into it as a one-piece assembly. If the steel disk is not present in the ceramic insert, place the steel disk on the crucible ceramic insert and check for proper seating. Remix bag of CADWELD® filler material and fill crucible according to the instructions on page 7.



12. Position crucible on the pouring basin and secure the tiedown chain, keeping it just loose enough to allow swivelling of the crucible without tipping.



13. Open the starting material container. Evenly distribute the starting material over the filler material in the crucible, saving a small amount to be placed on the tab of the crucible extension. Place the crucible extension on the crucible and put the remainder of starting material on the tab. Place the crucible cover on the extension. Standing off to the side of the opening and up wind, ignite the starting material on the tab.



14. Keep the tiedown chain secured at all times. **Immediately** after the sleeve has filled, slowly swivel the crucible back and forth to break the slag between the base of the crucible and top of the pouring basin. Repeat after 15 or 20 seconds as necessary.

After the slag has solidified, release the tiedown chain and remove the crucible. All other parts can then be removed.



15. Clean the crucible by turning upside down and placing a metal rod (#5 [16mm] rebar) against the ceramic and **lightly** tapping the rod end to discharge the slag and ceramic into a suitable waste container.
16. Break off riser with hammer. Clean slag from crucible and pouring basin as soon as possible to promote cooling. Use a whisk broom, rag or wooden wedge for cleaning. Do not use a wire brush. Cover and crucible extension need not be cleaned every time.

NOTE: Clean flash or debris from all mating surfaces as debris can cause springing of the equipment clamps and hinges.

Instructions For Horizontal Splicing

1. Clean rebar ends as per "Rebar Cleaning Procedure" on page 2.



2. Slide splice sleeve over bar before placing rebar into position for splicing.

The average gap between bar ends should not exceed 1/4-in. (6mm). If a natural gap is not provided by the shape of the reinforcing bar ends, a spacer can be used. The spacer is not required to remain in position.

Spacers are enclosed in an envelope in each carton of CADWELD® filler material. For certain conditions, a spacer may be omitted. Contact ERICO® for additional information.



3. Position splice sleeve by placing tap hole directly in line with the gap between the bar ends.

Lift the splice sleeve completely and drive down the vent pins. The splice sleeve need not be concentric with the rebar.

For sleeves without vent pins, please see page 8.



4. Place a double wrap of packing material around rebar, against both ends of sleeve. The second wrap of packing should be placed alongside the first. **DO NOT** force packing into splice sleeve.



5. Place end alignment fitting around rebar. Lock and slide into position against packing and sleeve. Be sure that the fittings slide over the ends of the sleeve.



6. Place horizontal packing clamp in position. (Normally it will hang from the rebar.) Draw bar must not block access to the sleeve tap hole.

Tighten hand knob on end of clamp to draw end alignment fittings firmly into position over sleeve ends. This action wedges the packing against the sleeve and rebar to prevent leakage of filler material.

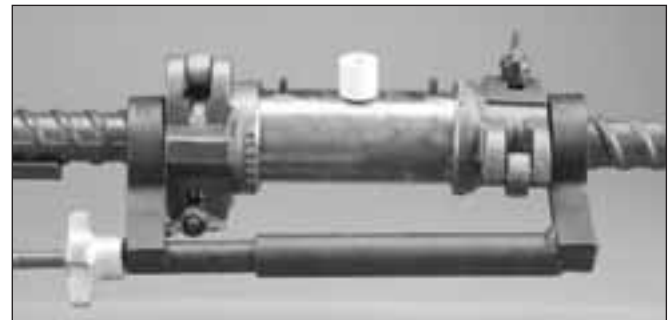

7. Position ceramic insert guide tube assembly firmly into tap hole, making sure it is completely seated in the tap hole.

8. Flame dry pouring basin and crucible before using. As a check, a drop of water should boil off rapidly.

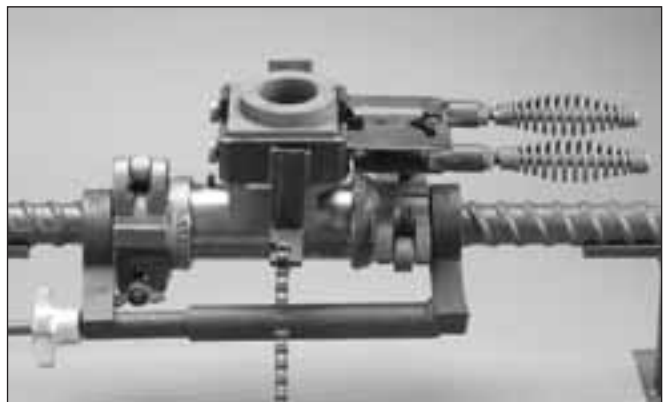

9. Place pouring basin into position on the sleeve. Place chain around sleeve and **finger tighten** thumb nut. Do not over tighten thumb nut.

Instructions For Horizontal Splicing

NOTE: A crucible should not be reused until allowed to cool for 15 minutes or more. If more frequent use is desired, several crucibles complete with frames should be used alternately to allow sufficient cooling time.

Clean crucible thoroughly inside. Empty the crucible completely. See Note 13 & 14 on this page for additional information. **Do not use a wire brush.**



Place crucible ceramic insert in bottom of crucible.

All crucibles use the same ceramic insert.

The crucible ceramic insert assembly is supplied with a steel disk pre-installed into it as a one-piece assembly. If the steel disk is not present in the ceramic insert, place the steel disk on the crucible ceramic insert and check for proper seating.

Remix bag of CADWELD® filler material and fill crucible according to the instructions on page 7.

10. Position crucible on the pouring basin and secure the tiedown chain. Keeping it just loose enough to allow swivelling of the crucible without tipping.



11. Open the starting material container. Evenly distribute the starting material over the filler material in the crucible, saving a small amount to be placed on the tab of the crucible extension. Place the crucible extension on the crucible and put the remainder of starting material on the tab. Place the crucible cover on the extension. Standing off to the side of the opening and up wind, ignite the starting materials on the tab.

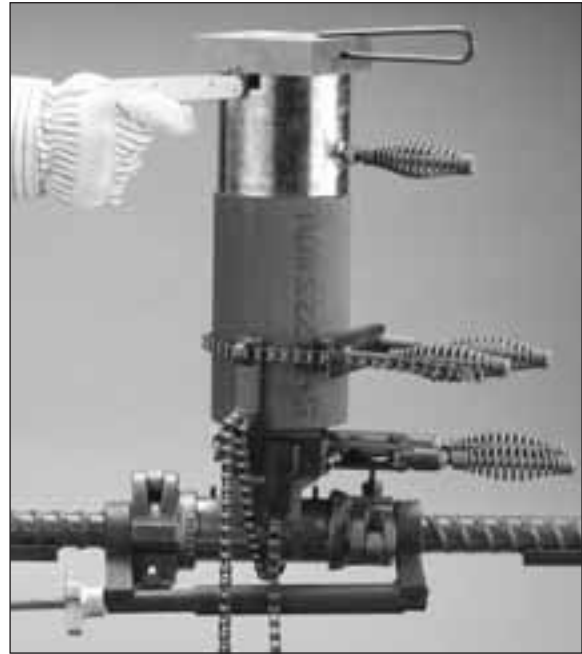

12. Keep the tiedown chain secured at all times. **Immediately** after the sleeve has filled, slowly swivel the crucible back and forth to break the slag between the base of the crucible and top of the pouring basin. Repeat after 15 to 20 seconds as necessary. After the slag has solidified, release the tiedown chain and remove the crucible. All other parts can then be removed.



13. Clean the crucible by turning upside down and placing a metal rod (#5 [16mm] rebar) against the ceramic and **lightly** tapping the rod end to discharge the slag and ceramic into a suitable waste container.



14. Break off riser with hammer. Clean slag from crucible and pouring basin as soon as possible to promote cooling. Use a whisk broom, rag or wooden wedge for cleaning. **Do not use a wire brush.** Cover and crucible extension need not be cleaned every time.

NOTE: Clean flash or debris from all mating surfaces as this causes springing of the equipment clamps and hinges.

Filler Material Remixing And Placement Procedures



1. Cut off top of bag just below closure tie. This will allow enough remaining bag length to permit remixing.



2. Open bag and then reclose to entrap air. (Starting material container may be removed if it is convenient.)



3. Fold over cut end of bag, leaving enough open space within the bag to allow free tumbling of filler material.



4. Using both hands, flip-flop the bag several times, allowing the filler material to remix.



5. Unfold bag and pour enough filler material into a prepared crucible to completely cover the crucible-ceramic and steel-disk assembly. Lift crucible up to ensure filler material is not leaking. (If it is leaking, carefully pour the filler material back into the bag and reseal the steel disk or replace if bent.)
6. Dump the remainder of the filler material into the crucible, taking care to remove the container of starting material if it is still in the filler material.

Instructions For Venting CADWELD® Horizontal Splices*

The use of wire or nails for venting is two-fold. Primarily, they raise or lift the sleeve from the top of the rebar, creating a gap between the sleeve and bar. The gap is necessary for proper fill at the top of a horizontal splice. Gravity takes care of filling the bottom of the sleeve.

The second purpose of the wires or nails is to provide a path for the escape of air from the inside of the sleeve. During splicing, air inside the sleeve is greatly expanded by the incoming molten metal. If this air is trapped in the sleeve, it takes up volume and will not allow the metal to fill correctly. Creating an avenue of escape (with the wires or nails) allows the metal to adequately fill the splice sleeve.

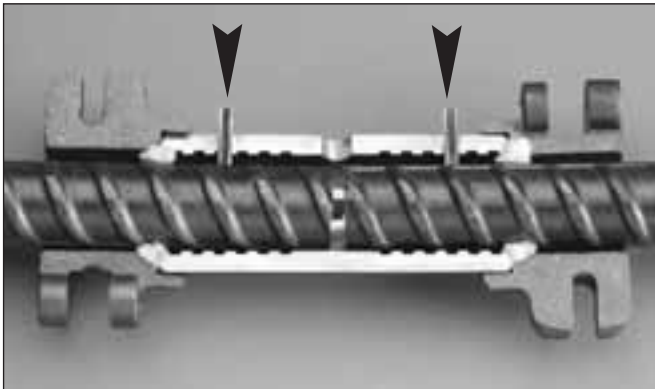

Venting with vent pins. Raise sleeve until it touches the bottom of the bar and firmly drive down vent pins with a hammer.

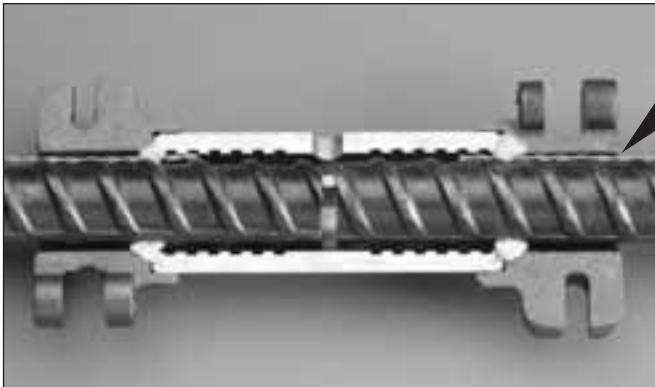

Venting with twisted tie wire. Place uncoated steel wire on top of bar. Wire should be long enough to protrude approximately 2-in. (50 mm) into sleeve and out beyond End Alignment Fitting as shown above.

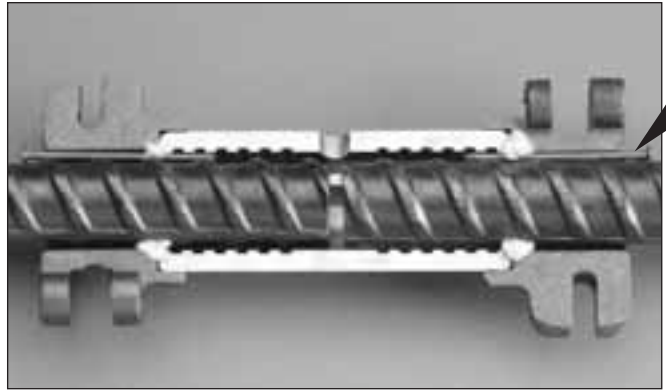

Venting with nails. Place uncoated steel nail on top of bar. Nail should be long enough to protrude approximately 2-in. (50mm) into sleeve and out beyond End Alignment Fitting as shown above.



Venting of B-Series structure splice with twisted tie wire. Place uncoated steel wire on top of bar. Wire should be long enough to protrude full length of sleeve and out beyond End Alignment Fitting as shown above.

*Formerly Bulletin 101

Inspection

Inspection of a CADWELD® splice is a visual process.

Properly made splices will have filler metal visible at both ends of the sleeve and at the Tap Hole.

Due to the gasket action of the packing, the filler metal will not always flow to the very edge of the sleeve. This condition is most prominent in splices that require use of the Horizontal Packing clamp which, when tightened, forces the packing into the sleeve. The bottom of a vertical splice will exhibit the same tendency due to the weight of the equipment forcing the packing into the sleeve.

This indent caused by the packing will vary from 1/8-in. (3 mm) to 1/4-in. (6 mm) in depth. Occasionally, where a loose end of the packing has been forced into the sleeve, the indent can vary from 3/8-in. (9.5 mm) to 1/2-in. (12.7 mm) in depth. See Figures 1 and 2 for illustrations.

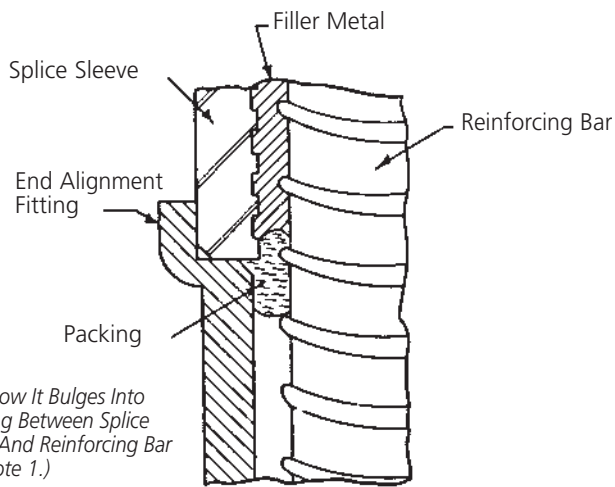

Figure 1

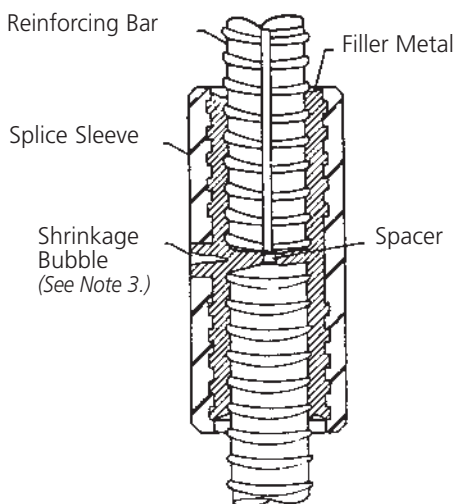

Figure 2

NOTES:

1. Do not manually force packing into sleeve. As described above, the packing will be forced into the sleeve by either the Horizontal Packing Clamp or by the weight of the splicing equipment.
2. When making vertical splices, it is important that the proper length packing be used at both the top and the bottom of the sleeve. The longer bottom packing (2-1/2 wraps) is used to seal the bottom of the sleeve while the shorter top packing (1-1/4 wraps) is loosely placed around the top of the sleeve in order to permit expanding air to escape and allow proper fill. Top packing should never be forced inside the sleeve.

Due to the loose top packing, filler metal will often flow above the top of the sleeve. This overflow is not detrimental to the splice and should not be a cause for rejection. In fact, an overflow is evidence of complete fill. It is not necessary to remove filler metal flash (collars) at the end(s) of the splice sleeves.

Adequate venting is essential for proper fill in all splice positions. See page 8 for recommended venting procedures on horizontal splices.
3. When the riser is removed, a shrinkage bubble may be exposed in the Tap Hole area. This bubble should not be distinguished from general porosity and shall not constitute cause for rejection.

Eccentricity And Cocking Of Rebars

If the splice sleeve is filled with sound metal, eccentricity, cocking and contact of rebars within the sleeve will have no effect on splice performance and are not cause for rejection. Standard splicing procedures for horizontal splices require lifting of the splice sleeve until contact is made with the bottom of the rebar.

Rejection Of A Splice And Its Causes

Improper Fill

Filler metal not visible at ends of sleeve – See “Void Limits.”

1. Filler metal leakage due to faulty use of packing or misalignment of equipment.
2. Excessive gap between the ends of the rebars or between the rebar end and the plate or structure to which a B-Series splice sleeve is welded. (Requires more filler metal to fill this space.)
3. Use of a smaller cartridge than called for or use of only part of the correct cartridge due to spillage when loading.
4. Undersize rebar requiring more filler metal to completely fill the sleeve. (Check the latest ASTM specification.)
5. Packing forced into the sleeve beyond the acceptable void limits.
6. If rebars are not clean and dry, gas or steam will be generated by the heat of the molten filler metal. This gas or steam can cause a blowout or general porosity and produce voids.
7. Improper placement of rebar ends in sleeve causing blockage of incoming filler metal at the Tap Hole.
8. Inadequate venting of Splice Sleeve. For vertical splices refer to Splice Kit Sheet for proper length of top packing (approximately 1-1/4 wrap around top bar). See page 8 for recommended venting procedures on horizontal splices.
9. Sound splices often have pin holes, shrinkage fissures and cold joints. These are usually visible at the ends of completed splices and are not cause for rejection.

Slag at Taphole

1. Omission of Steel Disk at bottom of Crucible.
2. Any one or more of items 1, 2, 3, and 4 under “Improper Fill.”

NOTE: When checking for filler metal at the sleeve Tap Hole, you cannot rely on color alone. When a hot riser is broken off, the exposed filler metal will oxidize almost immediately and discolor. If there is any doubt as to whether filler metal or slag is present in the Tap Hole, use a coarse file, prick punch or hammer to test. Filler metal will shine while slag will remain dull and crumble. Breaking off the riser may pull metal out of the sleeve Tap Hole. This should not be construed as an unfilled Tap Hole and is not cause for rejection.

Blowouts indicate that the cleaning practice for rebar ends should be reviewed

Power wire brushing and torch drying (as called for in standard instructions “Rebar Cleaning Procedure”) will help eliminate blowouts and severe voids.

Blowouts also can be caused by Splice Sleeves and other equipment being damp. This most commonly occurs when material is left out overnight or in the rain.

Void Limits

Splices shall be acceptable if the void per end does not exceed the limit listed below. Void areas are approximated as shown in the illustrations below. More exact void measurements should be made only when necessary.

Void Limits

Bar Size	Sleeve Number	Allowable Void			
		Column A (1) (2) Spot Voids		Column B (3) Full Circumference Low	
		(in ²)	(cm ²)	(in)	(cm)
#4	RBT5101A (HA) or RBB592JA	0.47	3.03	0.500	1.27
#5	RBT5101A (HA) or RBB592JA	0.53	3.41	0.500	1.27
#6	RBT6101A (HA) or RBB692JA	1.05	6.77	0.625	1.58
#7	RBT7101A (HA) or RBB792JA	1.03	6.64	0.562	1.42
#8	RBT8101A (HA) or RBB8101JA	1.02	6.58	0.500	1.27
#9	RBT9101A (HA) or RBB992JA	1.02	6.58	0.500	1.27
#10	RBT1091A (HA) or RBB1092JA	1.03	6.64	0.437	1.11
#11	RBT11101A (HA) or RBB11101JA	1.53	9.87	0.562	1.42
#14	RBT14101A (HA) or RBB14101JA	2.15	13.8	0.625	1.58
#18	RBT1891A (HA) or RBB1892JA	3.00	19.3	0.625	1.58
#6 to #7	RBT7101A (HA)	1.05 / 1.03	6.77 / 6.64	0.625 / 0.562	1.58 / 1.42
#7 to #8	RBT8101A (HA)	1.03 / 1.02	6.64 / 6.58	0.562 / 0.500	1.42 / 1.27
#8 to #9	RBT9101A (HA)	1.02 / 1.02	6.58 / 6.58	0.500 / 0.500	1.27 / 1.27
#9 to #10	RBT10901A (HA)	1.02 / 1.03	6.58 / 6.64	0.500 / 0.437	1.27 / 1.11
#10 to #11	RBT11101A (HA)	1.58 / 1.53	10.1 / 9.87	0.625 / 0.562	1.58 / 1.42
#11 to #14	RBT1114101A (HA)	1.53 / 1.52	9.87 / 9.80	0.625 / 0.625	1.58 / 1.58
#11 to #18	RBT1118101A (HA)	1.53 / 1.99	9.87 / 12.8	0.562 / 0.500	1.42 / 1.27
#14 to #18	RBT1418101A (HA)	2.15 / 1.99	13.8 / 12.8	0.625 / 0.500	1.58 / 1.27

□ = T-Series and B-Series ◻ = T-Series Transition

NOTES:

- Allowable accumulative void is shown for each end. For example, a splice of #18 bar in RBT-1891 is acceptable with a spot void 1 1/2-in. (38.1 mm) wide, 1 1/2-in. (38.1 mm) deep, and 5/16-in. (7.9 mm) low fill around remaining perimeter of bar. (Cumulative void area = 1.50 (1 1/2 - 5/16) + 7.09 (5/16 - 3/16) = 2.66 square inches [17.2 cm²].) The width (W) of any void is measured at the bar perimeter. There is a 3/16 in. (5 mm) allowance for packing.
- Use this column for all standard splices; vertical, horizontal, horizontal side fill, angled splices, and B-series structure splices with spot voids.
- Use this column for vertical splices only with low filler metal around entire circumference (for spot voids, use Column A). Applicable also for vertical B-Series Structure Splices with low filler metal around entire circumference.

NOTE:

Void dimensions can be established by use of a probe of tie wire.

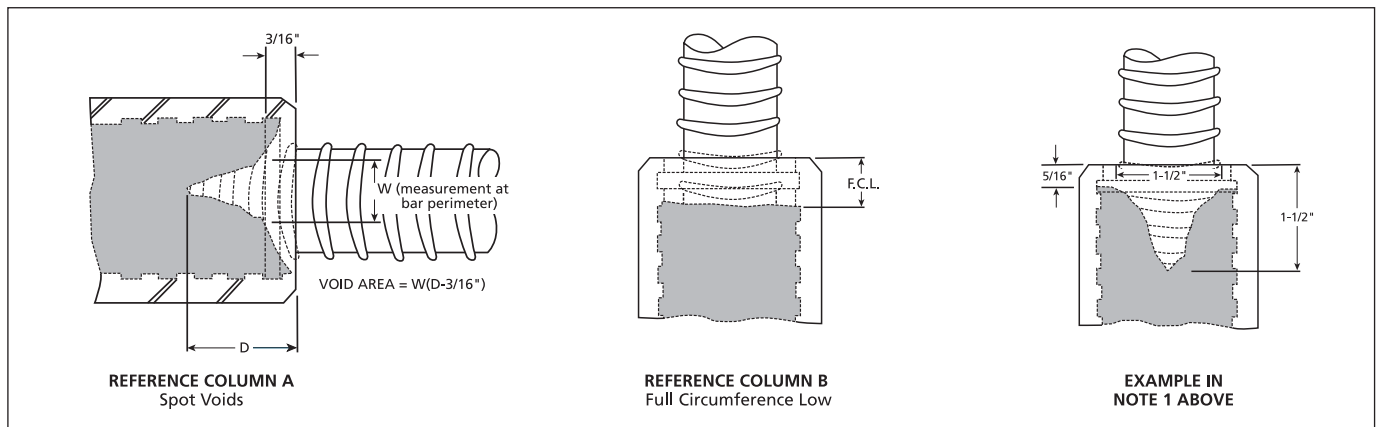

SUMMARY

The inspection of a CADWELD® rebar splice is visual. Occasional checking of the workmanship of the splicer to make sure that he or she is following the correct splicing procedure will serve to reinforce the judgement of the inspector on the job. ERICO® standard instructions should be consulted for additional information.

Additional Instructions For B-Series

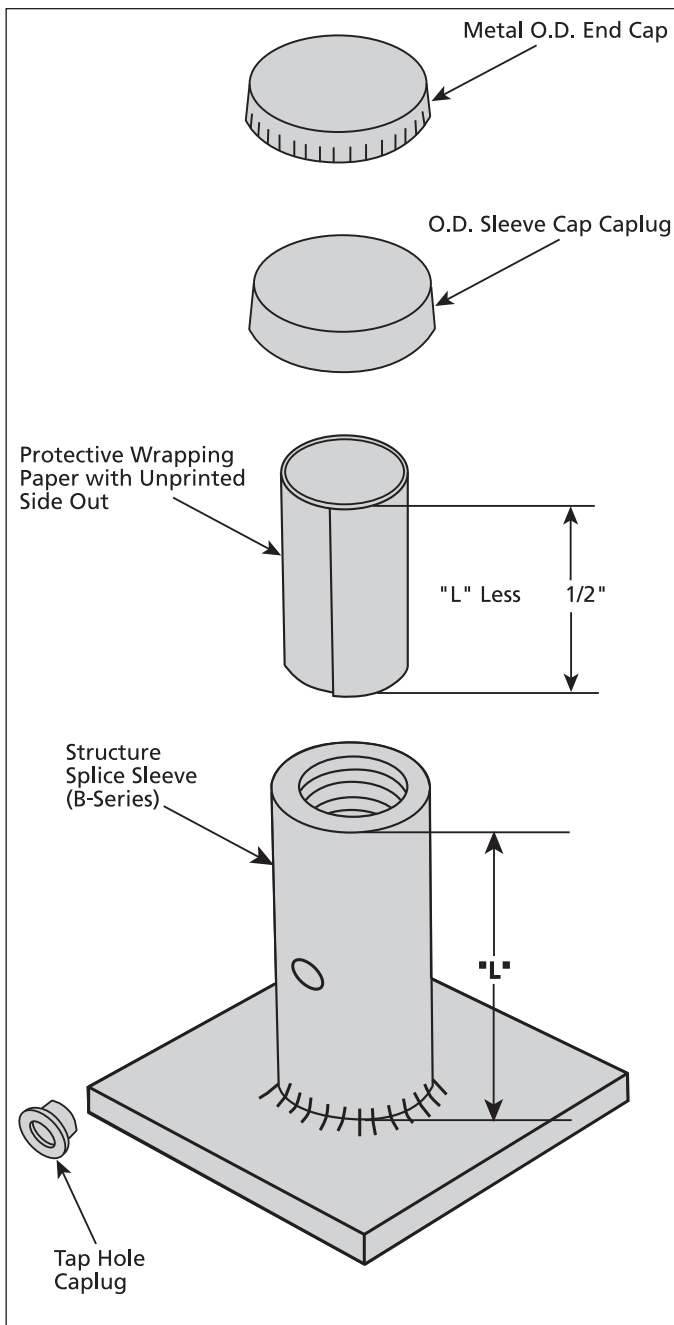

1. Leave protective wrappers on sleeves until ready to arc weld.
2. When removing protective wrappers, avoid tearing as wrappers must be inserted in sleeves after welding and before caplugs are installed as shown.
3. Cut or fold protective wrapping paper same length as the sleeve (splice sleeve original wrapping.)
4. Insert paper into sleeve with unprinted side out.
5. Place O.D. sleeve cap caplug over sleeve and tap hole caplug in tap hole (and vent hole plug in vent hole if required). See table in catalog for proper part number.
6. Caplugs must be kept tightly in place until removed for splicing bar in sleeve.
7. As an additional precaution against moisture, it is suggested that polyethylene sheet, tarpaulins, building paper or other protective cover be used to cover sleeves after welding and until they are spliced.
8. If CADWELD® splicing of the welded assembly will not occur for a week or more, it is recommended that the metal O.D. end cap be placed over the end of the sleeve and secured with all weather pipe tape to hold it in position. The metal end cap will protect against dislodging or puncturing of the plastic O.D. caplug.
9. When ready to complete the connection of rebar to the sleeve, remove end caps, plugs, paper and flame dry sleeve thoroughly.

NOTES:

1. O.D. sleeve cap caplug, tap hole caplug, and paper must be placed in sleeve as soon as sleeve has cooled after welding to effectively prevent internal rusting.
2. Part numbers for these accessories are listed in the catalog. See catalog for additional information.

Welding of Splice Sleeves to Structural Steel

Splice sleeves are generally arc welded to the structural steel in a fabricating shop. The design of the weld, the selection of the electrode, etc. depend on the chemical and physical properties of the structural steel to which the splice sleeves are welded. The engineer designing the assemblies should refer to the pertinent codes and recommended practices of the American Concrete Institute, American Welding Society, etc.

Care of Finished Assemblies

Following the instructions on this page, CADWELD® B-Series sleeves welded to the finished assemblies are covered to inhibit rusting and foreign contaminants from entering the sleeve interior.

Addenda

External Bar Reference Marks

Each bar should be marked some known distance from the end to provide an external means of checking the location of the bar ends within a completed splice. Any convenient distance may be used so long as the marks are visible outside of the splice sleeve. As an example, we have used the dimension of 12 in. (30.5 cm).

For inspection purposes, we recommend a plus or minus tolerance of 1/4-in. (6 mm) on each reference mark.

To prevent damage to the bar, we recommend using either permanent ink or paint as a marking material, blunt nose punch or draw file at the option of the engineer. Do not use prick punch or chisel.

Using our recommendations, the procedure would be as follows:

1. Prior to making the splice, an external reference mark shall be applied to each bar at a distance of 12 in. (30.5 cm) plus or minus 1/4-in. (6 mm) from the end of the reinforcing bar.
2. After the splice is completed, the distance between external reference marks shall not exceed $24\frac{3}{4}$ -in. (62.9 cm).
3. The midpoint of the distance between external reference marks shall lie within the diameter of the sleeve tap hole.

NOTE: When distance between reference marks is less than $23\frac{1}{2}$ -in. (59.7 cm), marks may not be within tolerance. A random check on reference mark locations should be made.

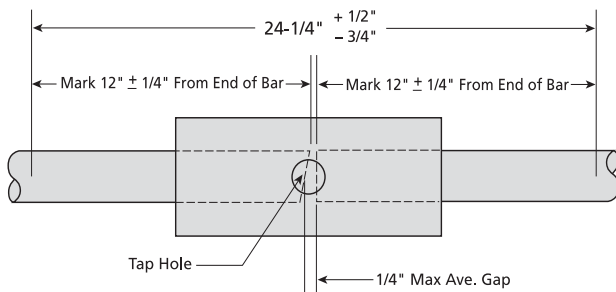

Bar End Gap

If a natural gap is not provided by the shape of the reinforcing bar ends, such as the tapered nature of shear cut bar ends or the tapered and uneven surface of flame cut ends, a spacer can be used to obtain a 3/16-in. (5 mm) to 1/4-in. (6 mm) average gap between the bar ends. An average gap is not restricted to a uniform gap.

In the horizontal position, a spacer can be used to set the average gap and then it can be removed. The spacer is not required to remain in position.

In the vertical position, when a natural gap is not formed by the shape of the reinforcing bar ends, a spacer may be used to provide a gap.

B-Series Sleeve Repair

Piggy-Back Repair

Repair of low filled structure splices can be accomplished by stacking or "Piggy-Backing" a second sleeve on to the end of the original sleeve. Depending upon construction conditions, the piggy-back sleeve may be a standard bar-to-bar splice sleeve, standard J-Groove structure splice sleeve, split bar-to-bar splice sleeve, or a split J-Groove structure splice sleeve. (Please see sketches on page 14.)

The principle behind the use of a bar-to-bar splice sleeve as the piggy-back repair is to completely fill the void in the initial sleeve and the new sleeve. Doing this only requires the use of a tack weld between sleeves. However, the filler metal cartridge must be adjusted each time to allow for the extra volume created by the voids in the initial splice.

The use of a J-Grooved structure splice sleeve enables the voids in the initial splice to be packed with inert packing material, eliminating having to calculate the void areas and adjusting the filler metal cartridge accordingly. A standard cartridge can be used each time. However, a structural weld between the initial and piggy-back sleeve is required to transmit the tension stress from the repair sleeve through the initial sleeve and into the structural plate or shape.

When it is not possible to slide a new sleeve over the loose end of the reinforcing bar, a split sleeve can be placed around the reinforcing bar and welded together forming a closed sleeve. This can be done using either a split bar-to-bar or a split structure splice sleeve, depending on which method of repair is used. When welding the split sleeve, care should be taken to prevent striking an accidental arc on the reinforcing bar.

Addenda (continued)

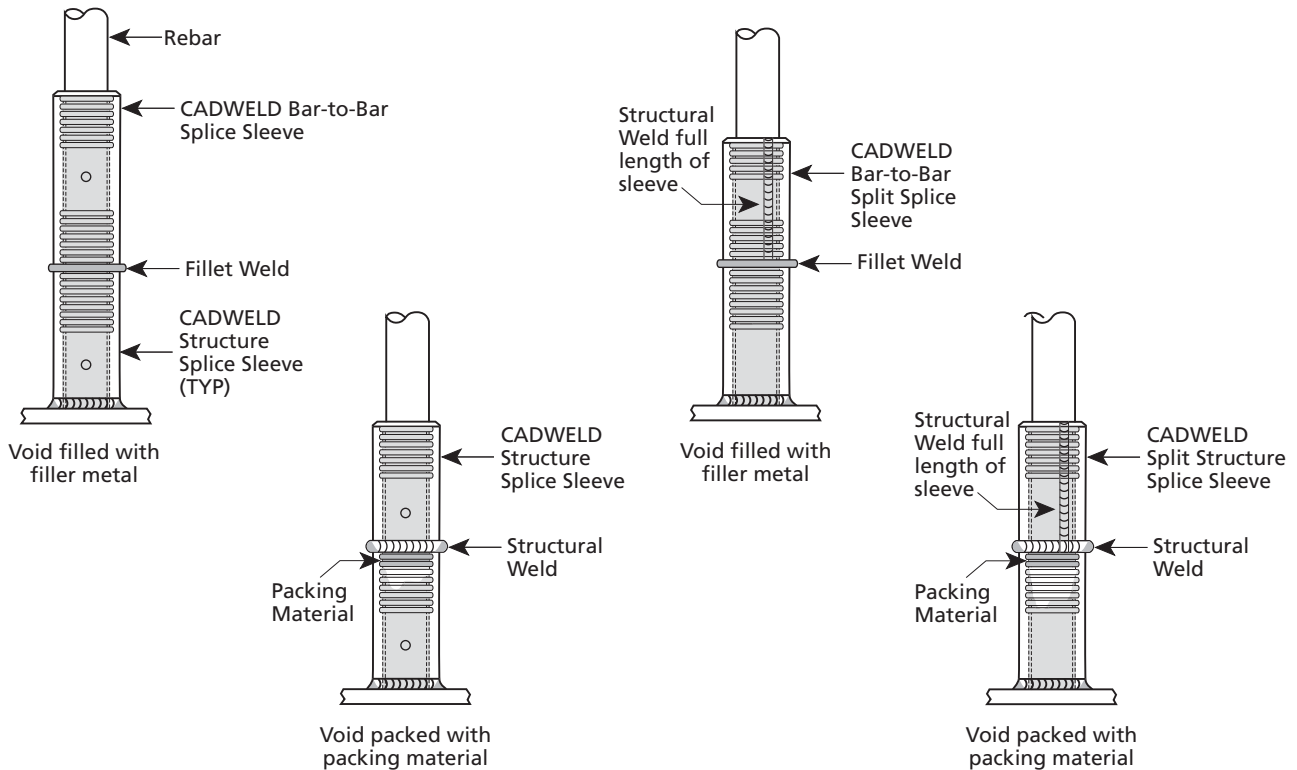

Tap Hole Relocation

Due to unforeseen clearance restrictions, B-Series sleeves are sometimes welded to structure assemblies with their tap hole oriented in the wrong directions, preventing the splicing equipment from fastening to the sleeve. In some instances the only method of correction is to redrill a new tap hole in a different location. This can be accomplished without altering the function of the splice sleeve as long as the following conditions are met.

1. The new tap hole should be the same size and distance from the end of the sleeve as the original tap hole.
2. When splicing a standard grade 60 (420 MPa) reinforcing bar, the abandoned tap hole should be plug welded using at least an E70XX electrode or equivalent.
3. Drilling of the new tap hole should always be accomplished without the assistance of cutting oils or other lubricants to prevent contamination of the splice sleeve and subsequent cleaning.

Erroded Tap Hole Repair

Improper seating of the pouring basin against the sleeve can cause filler metal or slag leakage to occur, eroding small amounts of the external splice sleeve surface. When it is impractical to remove the sleeve, strength integrity can be restored by building up the eroded area with at least an E70XX electrode or equivalent.

Cleaning Rusty Sleeves

To clean B-Series sleeves that are welded to structural assemblies and have become rusty, we recommend the following procedures:

1. Flame dry sleeves with torch to remove all moisture and/or burn away any other foreign matter. Flame should be soot free and not leave any residue or deposits on the inside sleeve surface. A "rose-bud" torch tip is recommended.
2. Using a solid end brush (contact ERICO® for brush size and information), and a pencil grinder with compatible revolutions per minute capacity, clean the inside sleeve and plate surfaces.
3. Any pitting in the grooves not cleaned by the end brush can be cleaned using a radial end brush (wheel brush). The wheel brush can be attached to an arbor and used in the pencil grinder.
4. Clean tap hole using a tube brush.
5. All brushes must be run dry. Lubricants or other abrasives should not be used.

Addenda (continued)

Use of Sleeves out of their Normal Position

The only difference between vertical and horizontal sleeves are the vent pins added to the horizontal sleeves. For this reason, horizontal sleeves can be used in the vertical position and vertical sleeves can be used in the horizontal position without losing splice integrity, providing the following procedures are followed:

1. Horizontal sleeves used in the vertical position require plugging of the vent pins to eliminate filler metal leakage. This can be accomplished by bending the vent pin over or bubbling the bent pin closed with a torch.
2. Vertical sleeves used in the horizontal position require the use of tie wire or nails to protrude underneath the packing material and out beyond the end alignment fitting. This will raise the sleeve off the bar surface and also create an avenue for the air inside the sleeve to escape. (Please see Venting Section on page 8.)

Repair of Bar-to-Bar Production Splice Samples or Rejected Splices

Following the requirements of Regulatory Guide 1.10 for removal of production splice test samples, it is necessary to replace the removed test piece with one or two additional splices. If the bar from which the sample was taken can be conveniently moved, the bar ends should be repositioned and spliced with a replacement splice. However, if the bar cannot be conveniently moved, the test sample will have to be replaced with two splices and a replacement bar the same length as that which was removed. The same procedures can be used for replacing rejected splices.

In congested areas, or for splices to short dowel lengths, it may not be practical to cut the reinforcing bar to remove the rejected splice. The only practical method may be to split the original splice sleeve with a cutting torch, remove the sleeve and filler metal and install another splice over the same length of bar. When splitting the splice sleeve, care should be taken to prevent damaging the reinforcing bar.

Traceability

ERICO® provides for material traceability of splice sleeves and filler metal. When required, splice sleeves are traceable to the manufacturer's original material certification.

Splice sleeves and their boxes and the filler metal cartridge boxes are marked to provide traceability.

WARNING

ERICO products shall be installed and used only as indicated in ERICO's product instruction sheets and training materials. Instruction sheets are available at www.erico.com and from your ERICO customer service representative. Improper installation, misuse, misapplication or other failure to completely follow ERICO's instructions and warnings may cause product malfunction, property damage, serious bodily injury and death.

WARRANTY

ERICO products are warranted to be free from defects in material and workmanship at the time of shipment. NO OTHER WARRANTY, WHETHER EXPRESS OR IMPLIED (INCLUDING ANY WARRANTY OF MERCHANTABILITY OR FITNESS FOR A PARTICULAR PURPOSE), SHALL EXIST IN CONNECTION WITH THE SALE OR USE OF ANY ERICO PRODUCTS. Claims for errors, shortages, defects or nonconformities ascertainable upon inspection must be made in writing within 5 days after Buyer's receipt of products. All other claims must be made in writing to ERICO within 6 months from the date of shipment or transport. Products claimed to be nonconforming or defective must, upon ERICO's prior written approval in accordance with its standard terms and procedures governing returns, promptly be returned to ERICO for inspection. Claims not made as provided above and within the applicable time period will be barred. ERICO shall in no event be responsible if the products have not been stored or used in accordance with its specifications and recommended procedures. ERICO will, at its option, either repair or replace nonconforming or defective products for which it is responsible or return the purchase price to the Buyer. THE FOREGOING STATES BUYER'S EXCLUSIVE REMEDY FOR ANY BREACH OF ERICO WARRANTY AND FOR ANY CLAIM, WHETHER SOUNDING IN CONTRACT, TORT OR NEGLIGENCE, FOR LOSS OR INJURY CAUSED BY THE SALE OR USE OF ANY PRODUCT.

LIMITATION OF LIABILITY

ERICO excludes all liability except such liability that is directly attributable to the willful or gross negligence of ERICO's employees. Should ERICO be held liable its liability shall in no event exceed the total purchase price under the contract. ERICO SHALL IN NO EVENT BE RESPONSIBLE FOR ANY LOSS OF BUSINESS OR PROFITS, DOWNTIME OR DELAY, LABOR, REPAIR OR MATERIAL COSTS OR ANY SIMILAR OR DISSIMILAR CONSEQUENTIAL LOSS OR DAMAGE INCURRED BY BUYER.

ERICO®



www.erico.com



AUSTRALIA
Phone 1-800-263-508
Fax 1-800-423-091



CHINA
Phone +86-21-3430-4878
Fax +86-21-5831-8177



HUNGARY
Phone 06-800-16538
Fax +39-0244-386-107



NORWAY
Phone 800-100-73
Fax 800-100-66



SWITZERLAND
Phone 0800-55-86-97
Fax 0800-55-96-15



BELGIUM
Phone 0800-757-48
Fax 0800-757-60



DENMARK
Phone 808-89-372
Fax 808-89-373



INDONESIA
Phone +62-21-575-0941
Fax +62-21-575-0942



POLAND
Phone +48-71-349-04-60
Fax +48-71-349-04-61



THAILAND
Phone +66-2-267-5776
Fax +66-2-636-6988



BRAZIL
Phone +55-11-3623-4333
Fax +55-11-3621-4066



FRANCE
Phone 0-800-901-793
Fax 0-800-902-024



ITALY
Phone 800-870-938
Fax 800-873-935



SINGAPORE
Phone +65-6-268-3433
Fax +65-6-268-1389



**UNITED ARAB
EMIRATES**
Phone +971-4-881-7250
Fax +971-4-881-7270



CANADA
Phone +1-800-677-9089
Fax +1-800-677-8131



GERMANY
Phone 0-800-189-0272
Fax 0-800-189-0274



MEXICO
Phone +52-55-5260-5991
Fax +52-55-5260-3310



SPAIN
Phone 900-993-154
Fax 900-807-333



UNITED KINGDOM
Phone 0808-2344-670
Fax 0808-2344-676



CHILE
Phone +56-2-370-2908
Fax +56-2-369-5657



HONG KONG
Phone +852-2764-8808
Fax +852-2764-4486



NETHERLANDS
Phone 0800-0200-135
Fax 0800-0200-136



SWEDEN
Phone 020-790-908
Fax 020-798-964



UNITED STATES
Phone 1-800-753-9221
Fax +1-440-248-0723